

Building Ramps and Handrails

To keep you safe at home

This handout gives instructions for building ramps and stair handrails for your home.

Ramps

Length and Slope

- Ramps should be at least 36 inches wide. If 2 people will be using the ramp at the same time, it should be at least 54 inches wide.
- Make your ramp 12 inches long for each inch of *rise* (slope). This is the most slope that is safe for someone in a wheelchair.
- The length of the ramp depends on the height of the steps. For example, if a set of steps is 3 feet (36 inches) high, you will need a 36-foot ramp (1 foot for every inch of rise).
- Make sure there is no more than 30 inches rise for each section of the ramp.



Make sure to build the ramp at least 36 inches wide to allow a wheelchair to move safely.

Landings and Platforms

- Build a level area at the beginning of the ramp. Make this first section 5 feet wide by 5 feet long.
- If the rise is more than 30 inches, a level platform or landing is needed partway up. Landings and platforms should be 60 inches (5 feet) long, and at least as wide as the ramp.
- Use *switchback* ramps if there is not enough room for a straight ramp. Switchback ramps should have a platform at least every 30 feet. The platforms should be 5 feet wide and 7 feet, 9 inches long, or double the width of the ramp.

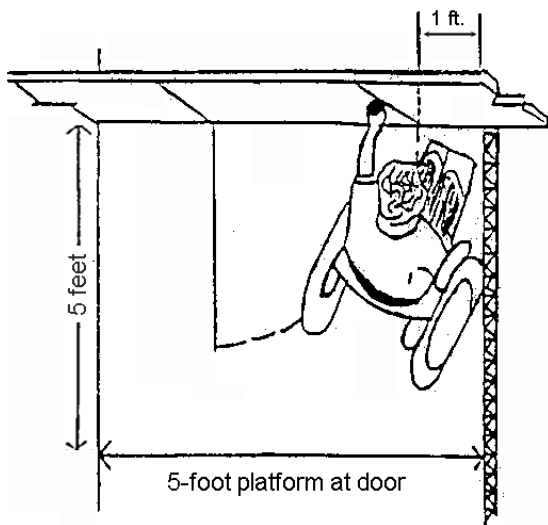

Opening a door from a wheelchair

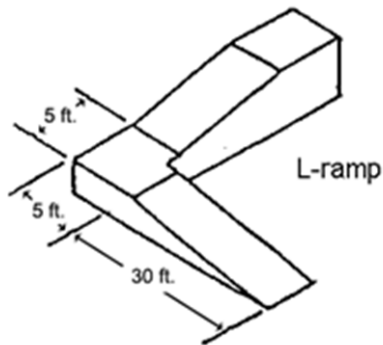

L-ramp

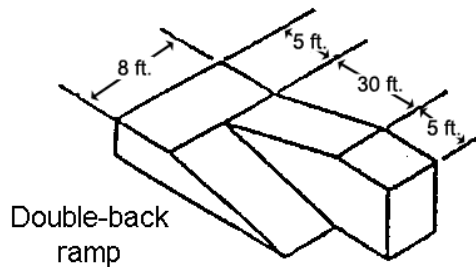

Double-back ramp

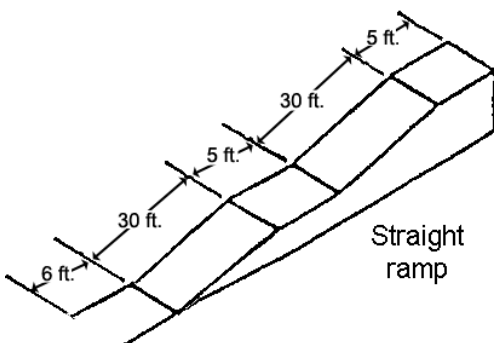

Straight ramp

Types of ramps and measurements

- You must have a platform at the door if the person using the wheelchair will open and close the door by themselves. If the door opens out, the platform will need to extend 1 foot beyond the doorknob side of the door.

Railings and Edges

- Place a low guardrail along the entire length of the ramp.
- The ramp should have at least 1 handrail, but 2 are best. The handrails should be 30 to 32 inches high and go 12 to 18 inches beyond the beginning and end of the ramp.
- The ramp edge (lip) should extend 4 inches above the ramp surface.

Ramp Surface

The ramp should have a hard, textured surface to prevent slipping. You can use:

- Commercial non-slip floor covering, such as rolled rubber matting
- Adhesive material
- A mixture of paint and silica sand
- 2-inch strips of non-slip material placed 2 inches apart

Other Ideas and Concerns

- Be creative. You may want the ramp to match the style of your house. You may also want to plant flowers and bushes along the sides of the ramp to help it blend with the rest of the yard.
- You can also buy portable, ready-made metal ramps. Check with your medical supply store. Ask your occupational therapist for more information.
- All thresholds should be less than ½ inch high. If they are higher, you will need to build a ramp.
- “Hill climbers” can be added to the wheels of your wheelchair to keep your chair from rolling backward. These may be needed on a steeper ramp, or you may need another person’s help for safety.

Stair Handrails

- Place rails on both sides of steps and stairs, if possible.
- Rails should be 30 to 32 inches high and go 12 to 18 inches beyond the top and bottom of the stairs.

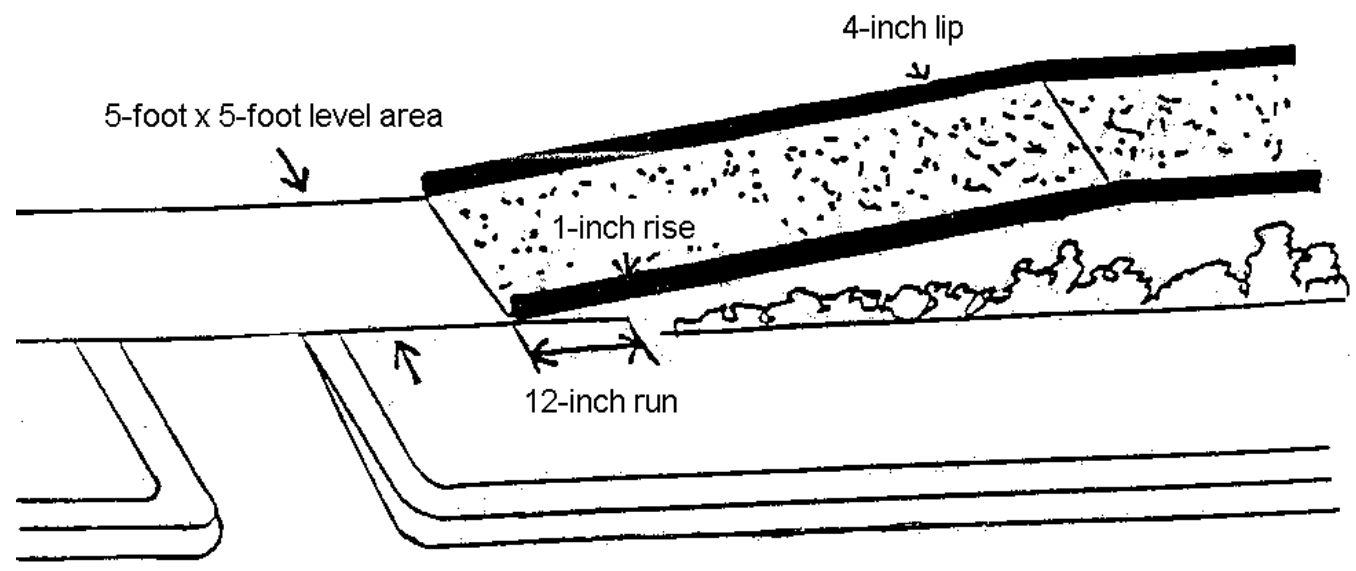
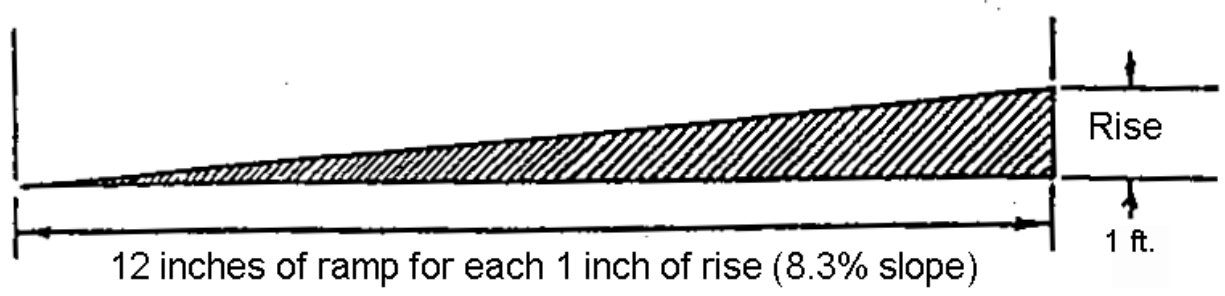
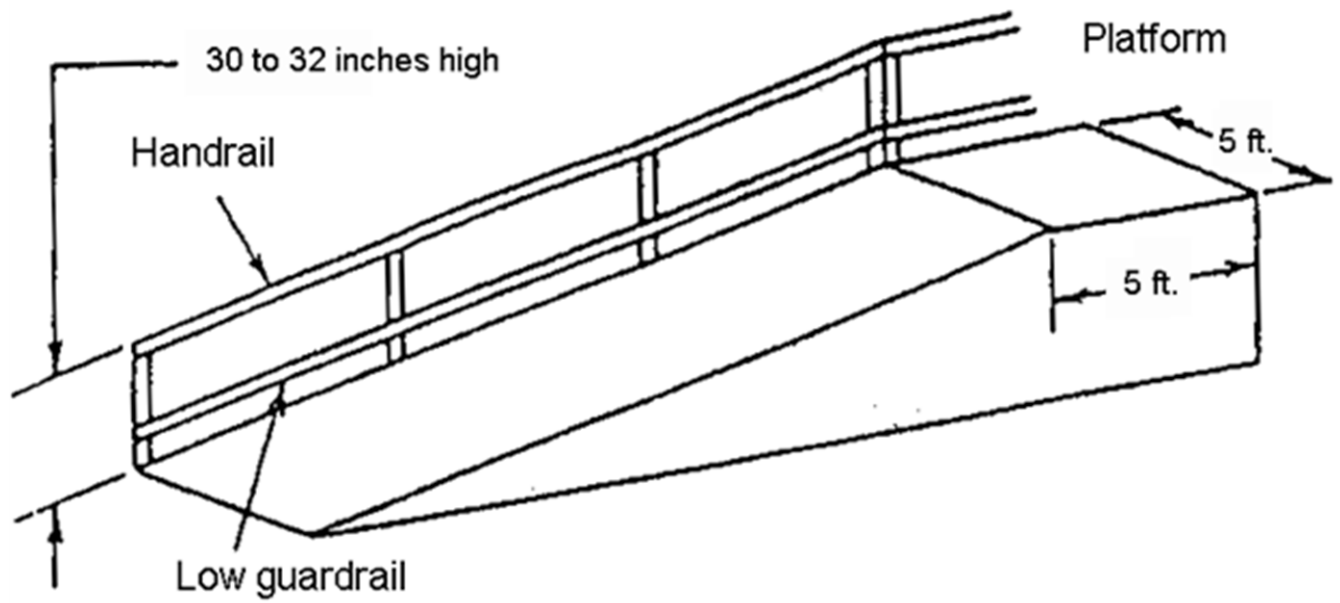

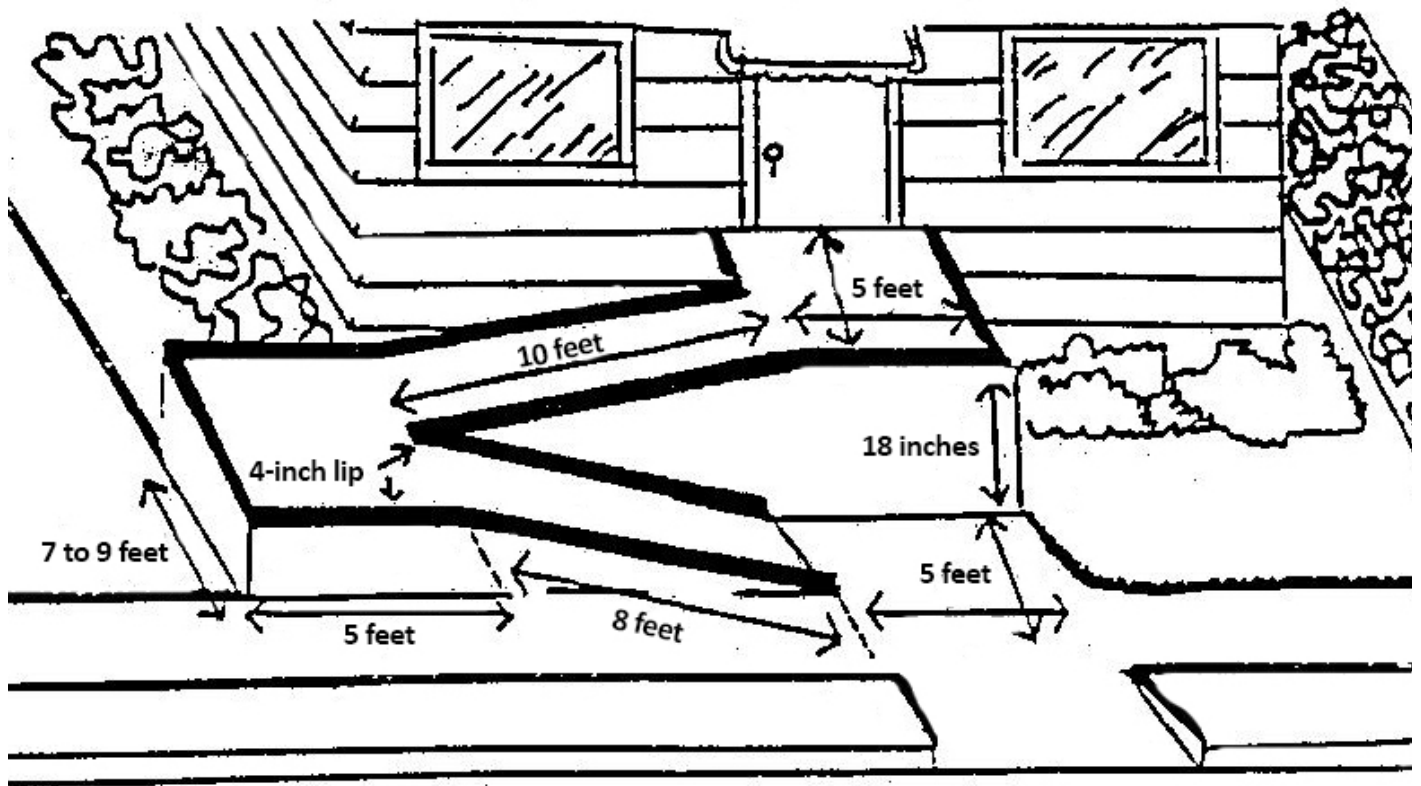

A complete ramp with measurements

Portions of this handout were adapted with permission from "Wheelchair Accessibility: Opening the Door to Housing, An Illustrated Manual," by Marilyn Whittmeyer, MOT, OTR, and Jim E. Barrett, MEd, University of Washington, Seattle, Washington 98105, 1977.

Questions?

Your questions are important. Call your doctor or healthcare provider if you have questions or concerns.

Occupational Therapy:
206.598.4830